

MAYORS

MERCHANDISE QUALITY MANUAL MAYORS ITEMS



Last Revised June 20, 2017

Table of Contents

INTRODUCTION	2
QUALITY ASSURANCE’S MISSION STATEMENT	3
SUPPLIER MANAGEMENT PROGRAM	3
SUPPLIER RATINGS - STATUS LEVEL.....	3
PRODUCT SELECTION PROTOCOL	4
General Guidelines.....	4
Product Marking Requirements	4
Manufactured Metal, i.e. Cast Or Stamped Components, etc.....	5
General Assembly	5
Stone Set Products	5
STANDARDS APPLICABLE TO ALL MAYORS ITEMS	6
TRADEMARKING REQUIREMENTS	6
MANUFACTURING STANDARDS	6
<i>METAL STANDARDS</i>	6
<i>METAL SURFACE</i>	7
<i>POLISHING</i>	7
<i>DIMENSIONS AND FINDINGS</i>	8
LOOSE STONES AND PEARLS	11
COLOR STONES STANDARDS	12
PEARL STANDARDS	15
MAYORS BRIDAL REQUIREMENTS	16
MANUFACTURING	16
MAYORS DIAMOND STANDARDS	17
CHILDREN'S JEWELRY AND ACCESSORIES REQUIREMENTS	18
AGE GROUPS.....	18
REGULATIONS.....	18
DIMENSIONS AND FINDINGS.....	19
DESIGN GUIDELINE FOR RATTLES	19

INTRODUCTION

This Merchandise Quality Manual reflects the current standards and practices applied to merchandise marketed under the Mayors name and distributed for sale at Mayors stores and other approved channels.

The Manual is to be used exclusively by Retail, Mayors Manufacturing, Marketing, Sourcing, Category Management, and approved Suppliers of Mayors merchandise.

Merchandise will be required to meet or exceed the minimum standards, by category, in the following sections of the Merchandise Quality Manual. All merchandise is subject to inspection, and that which does not meet the standards will be rejected and sent back to the supplier for repair, replacement or return. Penalties may be charged to the vendor for each rejection or repair of an asset piece.

QUALITY ASSURANCE'S MISSION STATEMENT

Quality Assurance is an independent service provider that ensures that the [Birks](#) and Mayors Quality Standards are consistent with the company's vision, standards and policies and supports the company's strategy and promise to the customer.

SUPPLIER MANAGEMENT PROGRAM

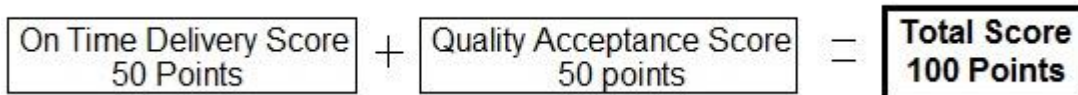

The measure for on-time delivery = percentage of units received within a week after due date - e.g. 90% on-time = 90% of 50 possible points (45)

The measure for Quality = percentage of units accepted made in monthly period - e.g. 98% units accepted = 98% of 50 possible points (49)

SUPPLIER RATINGS - STATUS LEVEL

Preferred Supplier: Total Score over 85
Approved Supplier: Total Score between 75 and 85
Conditionally Approved Supplier: Total Score below 75

PRODUCT SELECTION PROTOCOL

Quality Assurance reviews new products to verify conformance to Mayors' requirements as detailed in this Merchandise Quality Manual. This includes workmanship standards for fabrication, assembly, finish, gemstone standards, and stamping. Products are also reviewed for reliability, durability, and serviceability. Respectively, the product should perform as designed, have a reasonable life expectancy under normal conditions, and lend itself to routine maintenance.

Production samples must be reviewed and approved by Category Management and Quality Assurance prior to placing orders. Samples will be reviewed for aesthetics (how it compares to the design or original sample and how well it is finished), legal requirements, packaging and tested for function (how well it works). All pieces must comply with applicable requirements of this Merchandise Quality Manual.

Category Management and Quality Assurance must approve any change to a product during development in advance.

General Guidelines

- All gemstones and diamonds must be free from chips or scratches and must be set evenly and securely.
- Metals must be free from noticeable defects and distortions. They should be brightly finished and free from scratches and tarnish.
- All trademarks must be complete and legible
- All items must be adequately packaged to avoid damage In transit, with one item per single seal packet.

Product Marking Requirements

- All certificated diamond rings must have the certificate number and diamond weight marked inside the shank. Canadian diamonds must be laser engraved with Birks, maple leaf and certificate number on the girdle.
- All trademarks or stamp marks should be placed in an appropriate position, e.g. on rings marks should be placed high on the inside of shank away from the sizing area. If the shank has an inside recess these can be laser hallmarked inside the recess.
- No bruising or scrape marks caused by trademarking should be visible: products should be refinished after marking

Manufactured Metal, i.e. Cast Or Stamped Components, etc

- All metals must be free from visible defects and be finished to a high standard.
- There must be no visible porosity, pinholes, casting lines, file marks, stress cracks etc.
- All casting flash must be removed from all areas of the settings ensuring all openings are free from excess metal.

General Assembly

- All assembled parts of a product must be symmetrically aligned and be free from visible solder joints.
- There must be no excess solder on joints, no pinholes visible on joints and no discoloration where components are joined together.
- All products must be manufactured to the same design as the original sample. Any changes of components or alterations in design must be approved by Product Development Department.
- All products must be finished to a high standard, with no visible file or buffing marks.

Stone Set Products

- All stones must be set securely with no loose stones.
- All stones must be set level and seated correctly within the setting; particular attention should be given to channel settings.
- All stones set in claws should be seated straight with the girdle correctly positioned in the notch of the claw.
- All bezel and tension set stones must have sufficient material and consistent thickness placed over the girdle of the stone to keep secure.
- All claws must be uniform in size and shape and must be correctly aligned. They should be of sufficient length to secure stones but must not be bulky. They should be free from burs and smooth so will not catch on clothing etc.
- Certificated stones that have a laser inscribed girdle must be visible and not set behind a claw
- Channel settings must be level and straight, with the walls of equal thickness throughout.

STANDARDS APPLICABLE TO ALL MAYORS ITEMS

TRADEMARKING REQUIREMENTS

It is compulsory that any item stamped with a quality mark would be stamped with a Maker's trademark.

All suppliers must comply with all Federal regulations and other applicable laws with respect to precious metals markings (Highlighted in the Competition Bureau's Guide to the Precious Metal Marking Act).

All removable parts must be individually stamped.

If Jewelry cannot be stamped, a tag must be attached that contains the registered trademark and quality mark.

MANUFACTURING STANDARDS

METAL STANDARDS

Metal Fineness and Solder Requirements:

No variance from plumb will be accepted. That is, the fineness of the metal must be no lower than the fineness stamped on the piece.

Vendor represents and warrants that none of the gold or other minerals used in the manufacturing of the goods originate in the Democratic Republic of Congo or countries adjacent thereto.

A stamp indicating the true fineness of the metal is required on all merchandise fabricated with precious metal. By law, it must be paired with a Maker's Trademark.

All Silver pieces are expected to be treated against tarnishing by the Supplier.

Eighteen Karat gold	White Gold must pass nickel release testing. Solder must be plumb and blend properly with the surrounding gold. White Gold Solder must contain less than 0.05% lead.
Fourteen Karat gold	White Gold must pass nickel release testing. Solder must be plumb and blend properly with the surrounding gold. White Gold Solder must contain less than 0.05% lead.
Sterling Silver	Must be stamped 925 (ensure casting, findings are 925ppt, solder is 650ppt). Solder must have a fineness of at least 650ppt and not contain any lead.
Platinum	Solder must be any combination of Platinum, Palladium, Gold and Silver that does not result in an overall fineness below 900ppt.
Contemporary Metals	Approved contemporary metals must be stamped either with the full name of the metal or the metal's symbol on the Mendeleev Periodic Table.

METAL SURFACE

A normal level of porosity, consequence of the casting process, is tolerated to some extent on all pieces, regardless of value or metal type. If a silver or gold jewellery piece has porosity that is visible at a comfortable arm’s length (18”) and that affects the beauty and/or durability of the piece, it must be repaired before being accepted.

10 power or more magnification is used to evaluate porosity that threatens the structural soundness of a diamond or colored stone item. This includes thin areas such as prongs or links and micro-porosity that spread throughout the casting.

Ideal	Acceptable	Unacceptable
Not visible under magnification.	Minor porosity or small pinholes which do not affect the beauty and or the durability of the piece. Excluding prongs or a cluster of porosity. Pinholes barely visible to naked eye may be tolerated on silver items.	Porosity and pinholes and frosting visible without magnification, affecting the beauty or durability of the piece.

POLISHING

Pieces are to be polished to the highest luster possible except where inappropriate (i.e. Sandblast or matte finished pieces), and hard to reach areas. There must be no sharp edges or sharp points and polished surfaces should retain their original shape.

All white gold 18kt product must be rhodium plated.

Acceptable	Unacceptable
Brightness and uniform polish throughout the piece.	Dull luster, missed areas, parting lines and draglines.

DIMENSIONS AND FINDINGS

The following standards represent a general guideline to be used during the Sourcing process unless the Purchase Order specifies otherwise.

Type of Jewelry	Dimensions/Proportions		Findings
	Women	Men	
Rings	Stock size 6.5.	Stock size 10	
Necklaces, fixed pendants	Total length 16”- 18” (with shortening rings at 17” and 16”).	Total length 20”.	Lobster or approved fancy clasp.
Slide pendants	Chain total length 18” with shortening rings at 17” and 16”. ring at 1 1/2” from end ring	Total length 20”.	Lobster clasp.
Bracelets	Total length 7 1/2” with shortening rings at 6 3/4” and 6”.	Total length 8 1/2”.	Lobster or approved fancy clasp.
Pendants			Must have a chain unless it is charm
Bangles	Minimum inside 2” high, 2 2/3”. wide		
Stud earrings	Culet to be 1mm maximum from ear.		Post & butterfly.
Brooches	Brooch must sit in a balanced way.		Hinge at top or right, clutch at bottom or left.
Earrings Findings	<p><i>Silver earrings findings:</i> No sterling silver posts are allowed. Post they must be 14 karat white gold on all silver earrings.</p> <p><i>Silver earrings with gold accents:</i> the posts must be in white gold when soldered to white gold and yellow gold when soldered to yellow gold.</p> <p><i>Gold/Platinum earrings:</i> the posts must be made in a metal and karatage similar to the one used on the earrings.</p>		

Mayors is basing its inspection of ring sizes on the following chart:

Mayors Ring Size to minimum inside diameter chart

Ring size	Minimum inside ring diameter (in mm)
3.5	14.50
4.0	14.90
4.5	15.30
5.0	15.69
5.5	16.09
6.0	16.49
6.5	16.89
7.0	17.29
7.5	17.68
8.0	18.08
8.5	18.48
9.0	18.88
9.5	19.28
10.0	19.67
10.5	20.07
11.0	20.47
11.5	20.87
12.0	21.27
12.5	21.66
13.0	22.06
13.5	22.46
14.0	22.86
14.5	23.26
15.0	23.65
15.5	24.05
16.0	24.45

Bangles and Cuff Bracelets Dimensions

Bangles	Round Slip-On Bangle Bracelet	Standard	2.51" diameter (7.75"-8.00" Circumference).
		Small	2.41" diameter (7.45"-7.70" Circumference).
		Large	2.60" diameter (8.06"-8.31" Circumference).
	Round Hinged Bangle Bracelet	Standard	2.32" diameter (7.16"-7.41" Circumference).
		Small	2.15" diameter (6.64"-6.89" Circumference).
		Large	2.49" diameter (7.68"-7.93" Circumference).
	Oval Slip-On Bangle Bracelet	Standard	2.52" high x 2.32" wide (7.48"-7.73" Circumference).
		Small	2.42" high x 2.23" wide (7.45"-7.70" Circumference).
		Large	2.61" high x 2.40" wide (7.75"-8.00" Circumference).
	Oval Hinged Bangle Bracelet	Standard	2.40" high x 2.05" wide (6.88"-7.13" Circumference).
		Small	2.23" high x 1.90" wide (6.38"-6.63" Circumference).
		Large	2.58" high x 2.19" wide (7.38"-7.63" Circumference).
Cuff Bracelets	Oval Cuff Bracelet	Standard	2.00" high x 2.37" (6.75"-7.00" Circumference, 1.06" gap at the bottom).
		Small	1.86" high x 2.19" (6.25"-6.50" Circumference, 1.06" gap at the bottom).
		Large	2.15" high x 2.54" (7.25"-7.50" Circumference, 1.1" gap at the bottom).
	Oval Spring Cuff Bracelet	Standard	1.97" high x 2.32" (6.63"-6.88" Inside Circumference, 1.06" gap at the bottom).
		Small	1.83" high x 2.14" (6.13"-6.38" Inside Circumference, 1.06" gap at the bottom).
		Large	2.12" high x 2.49" (7.13"-7.36" Inside Circumference, 1.1" gap at the bottom).

LOOSE STONES AND PEARLS

DIAMONDS STANDARDS

If Canadian Diamonds are requested, diamonds must follow the rules of the Canadian Diamond Code of Conduct. Diamonds represented as Canadian to the customer must be laser engraved . The Canadian origin of the Diamond must also be mentioned on the invoice.

All loose or mounted diamonds, asset or memo, supplied to Mayors must contain the following statement on the associated invoice, in accordance with the Kimberley Process:

The diamonds herein invoiced have been purchased from legitimate sources not involved in funding conflict and in compliance with United Nations resolutions. The seller hereby guarantees that these diamonds are conflict free, based on personal knowledge and/or written guarantees provided by the supplier of these diamonds.

It is the responsibility of the vendor to disclose color and clarity information on the invoices to Mayors and to ensure the compliance of the diamond provided with this information.

Documentation supporting the information disclosed by the vendor on the invoices must be available to Mayors upon request.

As a general guideline, J-SI2 Quality should be considered a minimum quality for items distributed in Mayors stores.

No diamond having been processed through any kind of color or clarity treatment is acceptable to Mayors.

COLOR STONES STANDARDS

PRECIOUS COLORED STONES

Effective March 18th 2013, items will be rejected if they are not delivered with a GIA (Gemological Institute of America), AGL (American Gemological Laboratories), SSEF (Swiss Foundation for the Research of Gemstones), GRS (Gem Research Swisslab) Dunaigre or Gubelin report for every precious colored stone over a weight of three carats and/or with a cost over \$50,000.

The minimal level of detail on the certificate is Treatment Disclosure, Enhancement Disclosure and Identification. The certificate must not be more than three years old if the stone is indicated as not enhanced, and no more than seven years old if the stone is indicated as enhanced.

Invoices for such items must contain the following statement or will not be accepted:

“The products subject to this invoice fully comply with Mayors’ purchase order and with the Birks Group’s Merchandise Quality Manuals. The invoice fully discloses treatments, if any, applied to the products in accordance with the Standards described in AGTA’s 12th edition of the Gemstone Information Manual (Apr-2012)”.

SPECIFICS FOR EMERALDS

Emeralds are acceptable if they have:

- Oiling of emeralds using colorless oils (O code in AGTA’s classification)

Emeralds are not acceptable if they have:

- Surface coatings (C code in AGTA’s classification)
- Colored oils or other materials used as color enhancement (D code in AGTA’s classification)
- Opticon or similar resin treatments (W code in AGTA’s classification)
- Feathers reaching the surface that jeopardize the structure of the stone

SPECIFICS FOR RUBIES

Rubies are acceptable if they have:

- Standard heat treatments (H code in AGTA’s classification)

Rubies are not acceptable if they have:

- Diffusion coating (deep or shallow) (U code in AGTA’s classification)
- Colored oils or other materials used as color enhancement (D code in AGTA’s classification)
- Non-naturally occurring fillers in fractures/cavities and inclusions (F code in AGTA’s classification)
- Feathers reaching the surface

SPECIFICS FOR SAPPHIRES – including, without limitation, Padparadscha, yellow, lavender and pink sapphires

Sapphires are acceptable if they have:

- Standard heat treatments (H code in AGTA's classification)

Sapphires are not acceptable if they have:

- Diffusion coating (deep or shallow) (U code in AGTA's classification)
- Thin film coatings (C code in AGTA's classification)
- Colored oils or other materials used as color enhancement (D code in AGTA's classification)
- Non-naturally occurring fillers in fractures/cavities and inclusions (F code in AGTA's classification)
- Feathers reaching the surface

COLORED STONES GRADING POLICY

The nature of the stone will be taken into consideration during the finished item inspection. However, noticeable included crystals, fingerprints, feathers, color zoning, clouds or other aspects affecting either or both the appearance and durability of the stone will cause rejection.

Color Stones Requirements

Stone	Acceptable	Non acceptable
Amber	Standard heat treatment to clarify or produce spangles.	Reconstituted reformed, pressed, dyed.
Amethyst	Standard heat treatment.	Enhancements other than Standard heat treatment.
Aquamarine	Standard heat treatment.	Non-natural fractures/cavities or inclusion fillers.
Beryls	Oiling using colorless oils.	Surface coatings, colored oils or other materials used as color enhancement, opticon or similar resin treatments.
Chrysoberyl	Irradiation for Cat's Eye.	Unsafe levels of residual radiation.
Cameo	Whole pieces made of stone or shell and meet stone minimum requirements.	Assembled pieces or dyed.
Chalcedony	Standard heat treatment or dyed black (for onyx only).	Assembled pieces or dyed other than black for onyx.
Citrine	Standard heat treatments.	Coated or dyed.
Coral	Natural colors and solids.	Dyed, assembled or protected species.
Garnet	Heat treatment on Demantoids.	
Jade	Standard waxing (A Jade for Jadeite).	Bleaching, heating, dyeing, polymer impregnation (B and C Jade for Jadeite).
Lapis Lazuli	All natural only with a waxed surface.	Dyed, sealed with any stabilizers, reconstituted / reformed.
Opal	Oiling using colorless oils. Dye for Matrix.	Plastic Impregnation.
Tourmaline	Standard stone requirements and / or irradiation.	Fissure / fracture fillers or unsafe levels of residual radiation.
Tanzanite	Standard heat treatment.	Surface coating.
Topaz	Standard heat and irradiation treatments.	Diffusion treatments, surface coatings, or unsafe levels of residual radiation.
Tourmaline	Standard heat and radiation treatments.	Surface coatings, acid treatments, plastic or epoxy fillers.
Turquoise	Wax impregnation.	Impregnated with plastic, dyed, epoxy-backed or filled. Surface coatings or any stabilizer.

PEARL STANDARDS

The following standards apply for the grading of strung, mounted, or glued cultured pearls supplied to Mayors:

Lighting: Daylight equivalent fluorescent lighting against a neutral background.

Conditions: Unaided eye, at arm's length (18"); use 10X magnification to verify observations, e.g. missing nacre.

Generic Standard

Use of cultured pearls exhibiting any of the following characteristics is prohibited:

Chips on pearl surfaces Cracks in nacre Gaps in pearl nacre near drill hole, shaved areas on pearl surfaces, dull spots on pearl surfaces, missing nacre on a "dimple", seed banding or spotting as seen through the nacre-"blinking", scratches and/or scuff marks, dye concentration. Considerations related to size, shape, spotting, stranding, and matching issues will be discussed addressed by Quality Assurance and could cause the rejection of the piece.

MAYORS BRIDAL REQUIREMENTS

Unless specified otherwise thereafter, all standards from the previous sections of the Merchandise Quality Manual including, but not limited to, requirements related to Canadian Diamonds, Trademarking and Dimensions, also apply to Bridal.

MANUFACTURING

- On comfort fit rings, the exterior limit of the narrowest part of the ring must be centered over the appropriate line on the mandrel. That is, the finger size is measured slightly over the bottom of the ring.
- On wide bands with regular fit, the middle of the ring must be centered over the appropriate line on the mandrel. That is, the finger size is measured from the middle of the ring.
- Trademarks should be stamped away from the bottom of the rings to allow enough space for engraving and sizing.

MAYORS DIAMOND STANDARDS

Diamonds must be natural, no synthetic or lab-grown diamonds

Color: D-J

Clarity: IF-SI2

Proportions:

- Cut: Very Good to Excellent

Finish:

- Polish: Very good to Excellent
- Symmetry: Very good to Excellent

Fluorescence:

- none to medium

Other Parameters: Diamonds will **not** meet Mayors standards if they have:

- Being processed using GE treatment (High Temperature/High Pressure), or any other treatments to enhance colour or clarity
- Any fracture filling
- Any laser drilling
- Any open marks (cavities, pits, open feathers) on the surface of the diamond
- Reflecting crystal(s) in which multiple images are seen (in case they are easily noticeable)
- Large extra facets/large naturals or indented naturals
- Black/dark included crystal/s are accepted subject to overall valuation/look of the stone, special flexibility for diamonds over 3ct carat size

CHILDREN'S JEWELRY AND ACCESSORIES REQUIREMENTS

Unless specified otherwise thereafter, all standards from the previous sections of the Merchandise Quality Manual including, but not limited to, requirements related to Canadian Diamonds, Trademarking and Dimensions, also apply to Children's Jewelry and accessories.

AGE GROUPS

- Child between 0 and 5 years old
- Child over 5 years old

REGULATIONS

- All children's Jewelry must be in compliance with BS EN 71-3 part 3 Safety for toys Migration of certain elements (applies to products to the destination of children between 0 and 5 years old).
- All Mayors and Third Party Brands Children's Goods must exceed all the requirements noted in the Code of Federal Regulations, Chapter 16, part 1500, subchapter C "Federal Hazardous Substance Act Regulation."
 - o China - All Mayors and Third Party Brands Children's goods china must be manufactured with lead-free bodies, glaze and decoration. All Children's Goods china must be below the California Warning limits (0.226ppm for flatware and 0.100ppm for hollowware) for lead release, and for cadmium release 0.5 ppm flatware, 0.322ppm small hollowware 0.084 ppm large hollowware.
 - o Rattles - all Mayors and Third Party Brands rattles must pass all use, abuse, sharpness and esophagus tests as noted in the Code of Federal Regulations, Chapter 16. part 1511.8. Noise-maker beads may only be ceramic. No lead or cadmium based solders are allowed. Plug designs for electroformed rattles must be specifically approved by Quality Assurance.
 - o Other - All Children's Good items must pass the small parts test and any use and abuse, and sharpness tests as noted in the Code of Federal Regulations, Chapter 16, part 1501.4.
- Assay results coming from a laboratory approved by the US Consumer Product Safety Commission must be available to Mayors upon request for all items supplied.

DIMENSIONS AND FINDINGS

The following standards represent a general guideline to be used during the Sourcing process unless the Purchase Order specifies otherwise.

TYPE OF JEWELRY	DIMENSIONS/PROPORTIONS		FINDINGS
	0-5 years	5 years and over	
Rings	Stock size 3.5.		
Necklaces, fixed pendants	Total length 15" (with shortening ring at 14").	Total length 16" (with shortening ring at 15").	Lobster or approved fancy clasp. All Jump Rings soldered.
Slide pendants	Pendant not removable from the chain.	Pendant can be removable at the jump ring.	Lobster or approved fancy clasp. All Jump Rings soldered.
Bracelets	5" with no extension.	Total length 6" (with shortening ring at 5").	Lobster or approved fancy clasp. All Jump Rings soldered.
Bangles	1 1/2" from side to side.	1 1/2" from side to side.	
Earrings	<ul style="list-style-type: none"> - Hoop earrings between 10 and 15mm. - Stud earrings with posts between 7 and 11.5mm. - Drop earrings must have all jump rings soldered and drop close to earlobe. 		Posts in 14k gold for Silver and 14k gold items, and in 18k for 18k items.

DESIGN GUIDELINE FOR RATTLES

I. Scope and Purpose: - This specification is to be referenced by Mayors Category Managers, and inspectors.

Its purpose is to provide criteria for determining the minimum allowable physical size of a child's rattle for passing a series of shape and size tests regarding choking, aspiration, and ingestion hazards.

This specification applies to completed assemblies in whole or in part, both before and after "use and abuse" testing as outlined in the Standard Consumer Safety Specification on Toy Safety.

This specification does not attempt to cover all aspects of safety concerning children's products. For a more thorough understanding of children's product safety, it is recommended that the reader examine the Standard Consumer

Safety Specification on Toy Safety as well as any pertinent reference documents associated with it.

11. Definition - For purposes of this specification;

The term "rattle" refers to a child's toy, intended to be hand held, usually containing pellets or other small objects and which produces sounds when shaken.

"Ring type" rattle refer to a general torus or donut shaped geometry.

"Barbell type" rattles refer to rigid bars with nearly spherical, hemispherical, or circular flared decorative ends.

111. Requirement - No portion of any children's rattle shall be able to extend further past a depth of 1.18" (30.0mm) when inserted into an opening having the dimensions of **A** 1.38" (35.1mm) in width and 1.70" (43.2 mm) in length as shown in fig 1.

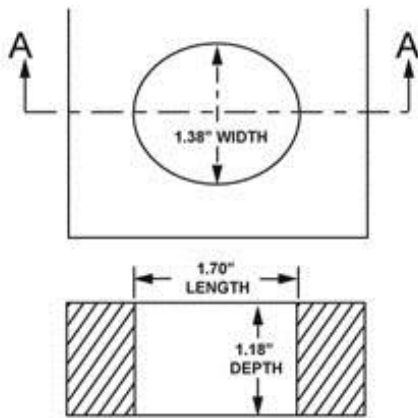

FIG. 1:
SECTION A-A
SCALE 1:1

No portion of a "barbell type" children's rattle shall be able to extend further past a depth of 1.18" (30.0mm) when inserted into a 1.68" (42.7mm) diameter opening as shown in Fig. 2

These two requirements are applicable before and after, "use and abuse" testing

In addition, no components or pieces, which have become detached from any children's rattle as a result of "use and abuse" testing, shall be small enough to fit

entirely within a 1.25" (31.7mm) diameter cylinder with a slanted bottom as shown in Fig. 3.

All requirements are valid when the item is tested under its own weight and in a noncompressed state.

All requirements are based on Title 16, Code of Federal Regulation, Part 15 10; Requirement for Rattles.

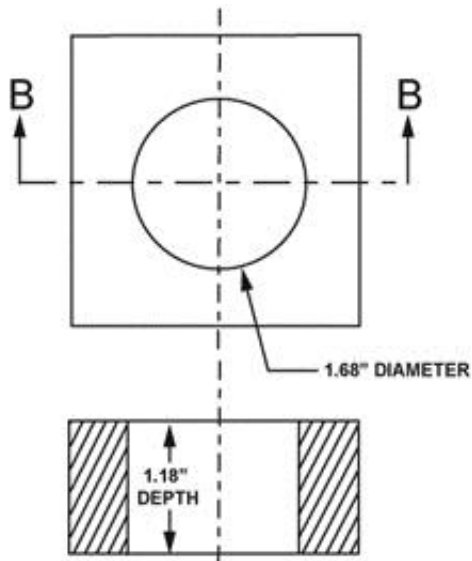

FIG. 2:
SECTION B-B
SCALE 1:1

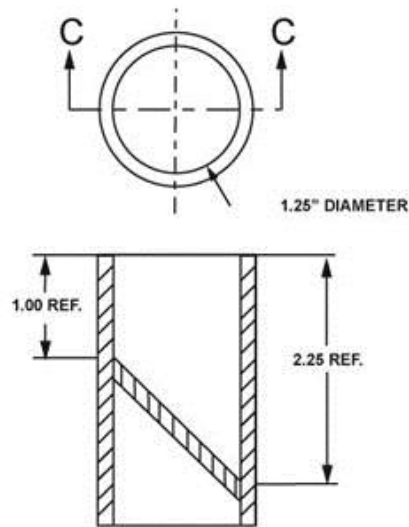

FIG. 3:
SECTION C-C
SCALE 1:1

IV. Application - Figures 4 through 6 depict rattle tested in an oval cavity having the dimensions specified in Fig. 1 Note the orientation shown is one that would most likely cause failure, as its position extends the most prominent feature into the cavity.

The pictorial and cross-sectional views, shown in Figures 5 and 6 respectively, show the rattle fully inserted into the cavity as far as possible, but not extending past the depth of the 1.18" cavity, making this rattle acceptable.

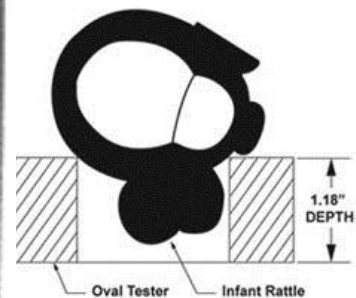
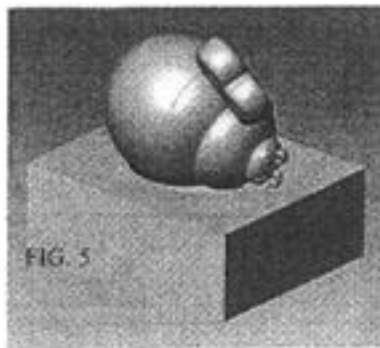
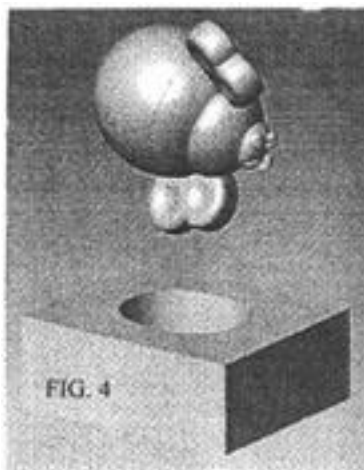

FIG. 6: